

DC-AC Inverter Circuit

Description

This document describes inverter circuits used for motor control and other applications, focusing on PWM control.

It also describes the differences between two-phase and three-phase modulation techniques as well as circuits for drive power supply and power losses in semiconductor devices.

Table of Contents

Description 1

Table of Contents 2

1. Inverters 4

 1.1. Need for an inverter for motor control applications 4

2. Control, commutation, and modulation methods for inverters 5

3. Voltage source type and current source type inverters 6

 3.1. Voltage source type inverters..... 6

 3.2. Current source type inverters 6

 3.3. Applications of voltage source type and current source type inverters in the market 6

4. Inverter modulation techniques..... 8

 4.1. Modulation techniques 8

 4.2. Advantages and disadvantages of PWM, PFM, and PAM 8

 4.3. Examples of PWM and PAM control circuits 10

5. 120° square-wave commutation vs. 180° sine-wave commutation 12

6. Two-phase and three-phase PWM modulation 14

 6.1. Three-phase PWM modulation 15

 6.2. Two-phase PWM modulation..... 17

 6.2.1. Control using both the upper and lower arms..... 17

 6.2.2. Control using only the lower arm..... 18

7. Miscellaneous information..... 20

 7.1. Multilevel inverters..... 20

 7.1.1. Three-level PWM 20

 7.1.2. More on three-level PWM..... 21

 7.2. Gate-drive power supplies (for three-phase inverters) 22

 7.2.1. Charge pump 23

 7.2.2. Bootstrap circuit 24

 7.3. Power losses (Three-phase modulation)..... 25

 7.3.1. Calculating the IGBT conduction loss P_{cond} 26

 7.3.2. Calculating the FWD conduction loss P_F 26

 7.3.3. Calculating the turn-on and turn-off losses (P_{on} and P_{off}) of an IGBT..... 27

 7.3.4. Calculating the FWD reverse recovery loss P_{trr} 28

RESTRICTIONS ON PRODUCT USE 29

List of Figures

Figure 1.1 Inverter concept.....	4
Figure 1.2 Inverter V_f characteristics	5
Figure 3.1 Voltage source type inverter.....	6
Figure 3.2 Current source type inverter.....	6
Figure 4.1 Overview of inverter modulation techniques	8
Figure 4.2 Examples of circuit block diagrams.....	11
Figure 5.1 Three-phase PWM inverter.....	13
Figure 5.2 Three-phase AC waveform and theoretical voltage waveforms of 120° and 180° commutation.....	13
Figure 5.3 Theoretical phase-to-phase voltage waveforms for 120° and 180° commutation.	14
Figure 6.1 Phase voltages in a three-phase inverter.....	15
Figure 6.2 PWM signal generation (sine-triangle pulse-width modulation)	16
Figure 6.3 Example of PWM signal generation.....	16
Figure 6.4 Three-phase inverter.....	17
Figure 6.5 Input voltage waveforms for two-phase modulation (Control using both the upper and lower arms).....	17
Figure 6.6 Two-phase modulation voltage waveforms.....	18
Figure 6.7 Neutral-point voltage during three-phase modulation	19
Figure 6.8 Neutral-point voltage during two-phase modulation.....	19
Figure 7.1 Three-level inverter control.....	21
Figure 7.2 Signals generated by a three-level inverter	21
Figure 7.3 Gate driver power supplies for a three-phase inverter	22
Figure 7.4 Charge pump circuit	23
Figure 7.5 Bootstrap circuit.....	24
Figure 7.6 Three-phase inverter circuit.....	25
Figure 7.7 IGBT switching waveforms and inverter operation.....	25
Figure 7.8 FWD reverse recovery waveform.....	28

List of Tables

Table 2.1 Types of inverters	5
Table 4.1 Advantages and disadvantages of PWM, PFM, and PAM	10
Table 6.1 Input voltage signals.....	17
Table 7.1 Comparisons of two- and three-level inverter circuits and their output voltage waveforms.....	20

1. Inverters

An inverter is a semiconductor-based power converter. An inverter that converts a direct current into an alternating current is called a DC-AC inverter. However, the term “inverter” generally refers to the equipment that combines an AC-DC converter (that changes an alternating current into a direct current) and a DC-AC inverter so as to be able to generate arbitrary frequencies and voltages. Figure 1.1 shows the concept of an inverter.

Homes, office buildings, and factories are supplied with AC electricity at various frequencies and voltages such as 50 Hz/100 V and 60 Hz/220 V. To drive electric motors efficiently, it is necessary to convert the mains supply into the optimal frequency and voltage. Emergency power systems convert mains AC power into DC power, store it in a battery, and, in the event of a power failure, convert it back into AC power as needed. Inverters are used for such applications.

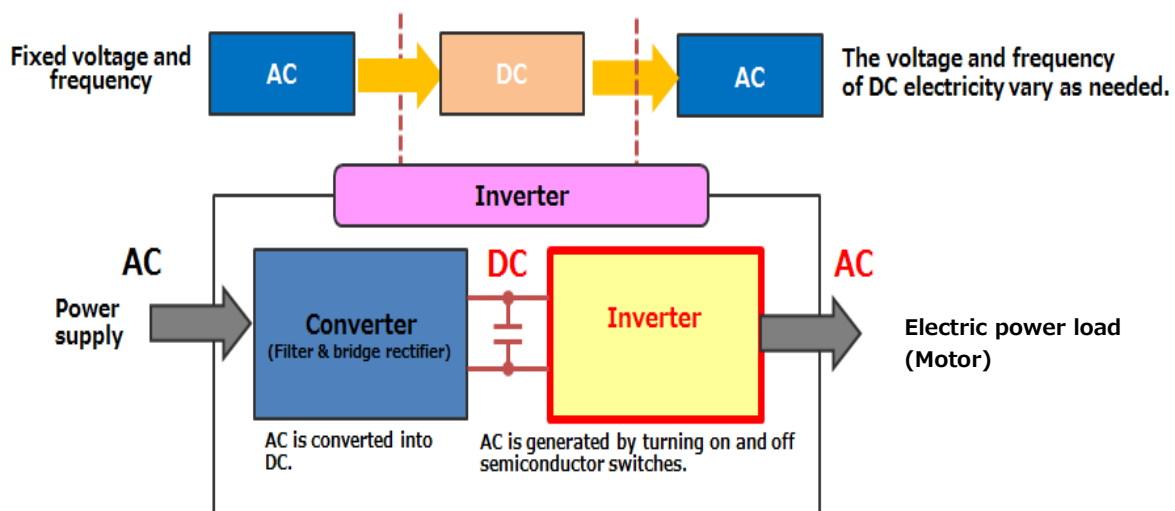

1.1. Need for an inverter for motor control applications

Rotation speed control of AC motors using an inverter

The rotation speed, or RPM, of a three-phase AC induction motor is represented by the following equation, which indicates that the RPM is **inversely proportional to the number of poles (P) and proportional to frequency (f)**. Motors have a fixed number of poles, which is a multiple of 2 such as 2, 4, and 6. Since an inverter is capable of dynamically changing the DC frequency, it is **most suitable for variable-speed motor control applications**.

$$\text{Motor rotation speed, } N \text{ (rpm)} = \frac{60 \times \text{frequency } f}{\text{Pole count } P/2} = \frac{120f}{P} \text{ (min.}^{-1}\text{)}$$

(Revolutions per minute: The unit of measure for the rotation speed is min.⁻¹.)

Vf characteristics of motors

Theoretically, the rotation speed of a motor can be controlled by varying only the frequency. However, unless both voltage and frequency are controlled,

1. an excessive current might flow into the motor at low RPM, causing mechanical damage; and
2. efficiency decreases.

Therefore, variable-voltage variable-frequency (VVVF) inverters are commonly used.

It is necessary for the output voltage (V) to increase linearly as the output frequency (f) increases.

Figure 1.2 shows the Vf characteristics of an inverter.

The voltage-to-frequency ratio is denoted as V/f.

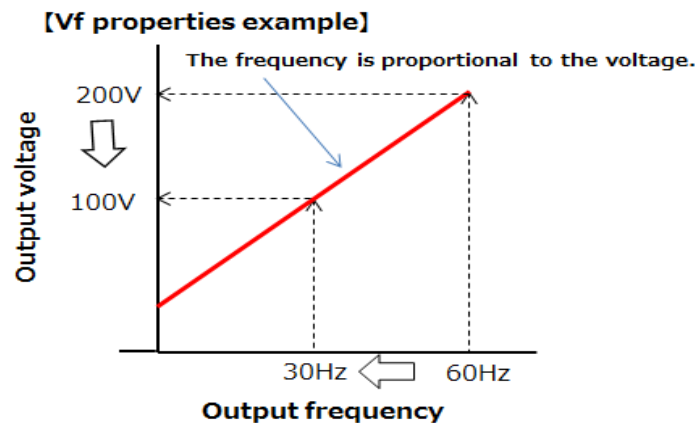

2. Control, commutation, and modulation methods for inverters

There are various types of inverter systems using different control, commutation, and modulation methods. Inverters can be categorized in many ways. Table 2.1 provides an overview of inverter categories. Voltage-type PWM inverters are most commonly used. These inverters are further divided into two categories, depending on the commutation method used: 120° commutation primarily used for small motor applications and 180° commutation used for many motor and power supply applications. There are two PWM modulation methods for 180° commutation: two-phase and three-phase modulation.

Control and modulation methods are selected according to the type of motor used, and its application area and requirements.

Table 2.1 Types of inverters

System	Modulation	Commutation	Application example
Voltage-Type inverter	PWM	Sine-wave commutation (180°commutation)	Two-phase PWM modulation Three-phase PWM modulation Inverter airconditioner General-purpose inverter UPS Inverter household appliance Compressor
		Square-wave commutation (120°commutation)	Small fan motor Pump for water heater
	PFM		Power supply
	PAM		Inverter household appliance Pump
Current-Type inverter			Supersized inverter (DC power transmission)

PWM : Pulse Width Modulation
 PFM : Pulse Frequency Modulation
 PAM : Pulse Amplitude Modulation
 UPS : Uninterruptible Power Supply

3. Voltage source type and current source type inverters

3.1. Voltage source type inverters

Voltage source type inverters control the output voltage. A large-value capacitor is placed on the input DC line of the inverter in parallel. And the inverter acts as a voltage source. The inverter output needs to have characteristics of a current source. In the case of low impedance load, series reactors are needed for each phase. (See L_1 to L_3 in Figure 3.1)

In motor applications, the leakage reactance of a motor fulfills the same function as this reactor. Reverse-conducting semiconductor devices that are capable of dealing with the back-EMF are commonly used as switches.

3.2. Current source type inverters

Current source type inverters control the output current. A large-value inductor is placed on the input DC line of the inverter in series. And the inverter acts as a current source. The inverter output needs to have characteristics of a voltage source. In motor applications, capacitors are required between each phase-to-phase of motor input (See C_1 to C_3 in Figure 3.2). (A large-value snubber is sometimes necessary to suppress surge voltage caused by an inductive load. In such cases, a snubber loss increases.)

This capacitor and motor inductance that work as a kind of filter reduce motor ripple current compared with the case of voltage source type inverters

Reverse-blocking devices such as thyristors are required as switching devices. In the case of using IGBTs and so on, series diodes are needed as shown in Figure 3.2.

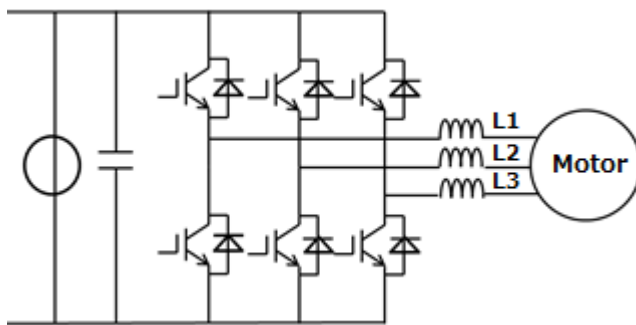

Figure 3.1 Voltage source type inverter

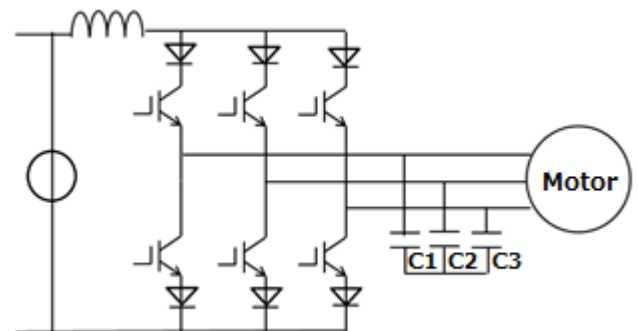

Figure 3.2 Current source type inverter

3.3. Applications of voltage source type and current source type inverters in the market

Voltage source type inverters are commonly used for all home appliance and industrial power applications. Voltage source type inverters are easier to control than current source type inverters. It is easier to obtain a regulated voltage than a regulated current, and voltage source type inverters can directly adjust the voltage applied to a load by varying the conduction ratio (i.e., the pulse width of a PWM signal). In addition, since

voltage source type inverters do not require any reverse-blocking diodes, they have less voltage drop and therefore provide higher efficiency than current source type

inverters. Furthermore, voltage source type inverters, which do not need a reactor on the DC side, can be made more compact than current source type inverters.

However, current source type inverters are still in use for some applications. For example, in high-voltage direct current (HVDC) transmission, a DC current travels a long distance before being converted back into AC. This means a DC current is supplied via a large reactor. Since the DC side must be treated as a current source, a current source type inverter is used for HVDC applications. Thyristors also remain in use in ultra-large inverters. Because of the reverse-blocking characteristics of thyristors, a current-mode configuration is sometimes used for such inverters.

4. Inverter modulation techniques

4.1. Modulation techniques

Three common techniques used to control (modulate) the power supplied to a load are pulse-width modulation (PWM), pulse-frequency modulation (PFM), and pulse-amplitude modulation (PAM). PWM is the most commonly used technique. PFM is hardly ever used for motor control applications.

1. **Pulse-width modulation (PWM):** A modulation scheme in which the pulse width (duty cycle) is varied to control the output power
2. **Pulse-frequency modulation (PFM):** A modulation scheme in which the number of pulses (i.e., frequency) is varied to control the output power. Also known as variable-frequency modulation (VFM)
3. **Pulse-amplitude modulation (PAM):** A modulation scheme in which the amplitudes (i.e., voltages) of pulses are varied to control the output power.

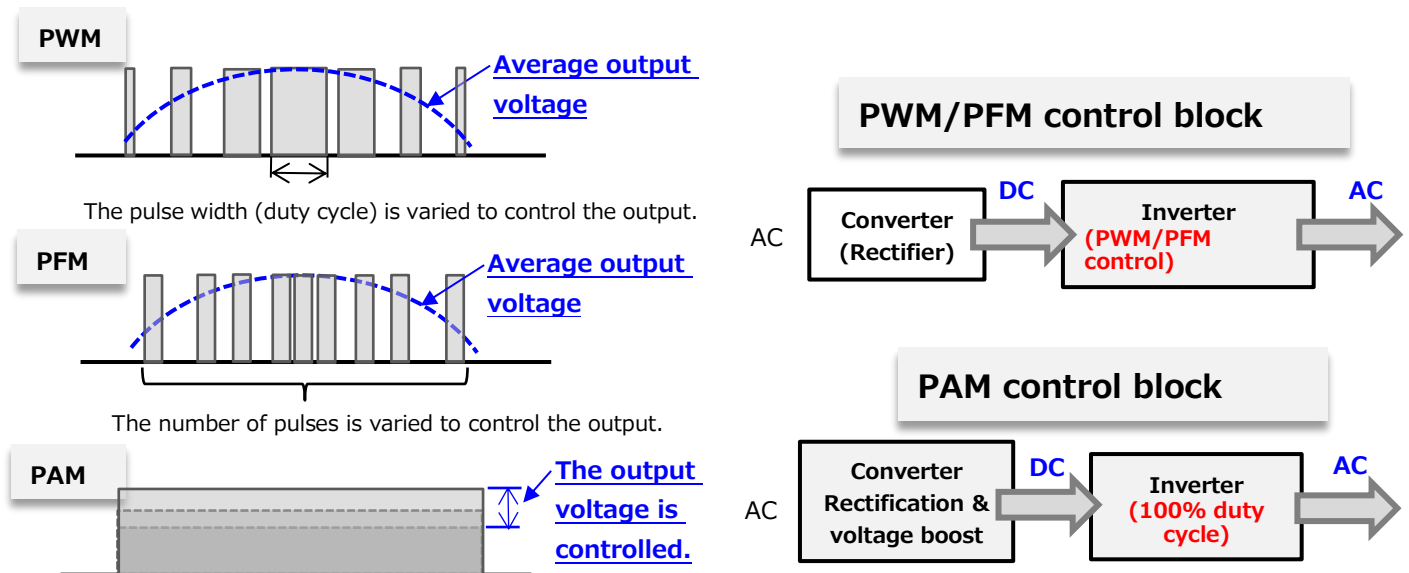

Figure 4.1 Overview of inverter modulation techniques

4.2. Advantages and disadvantages of PWM, PFM, and PAM

Most of the inverter systems for motor control applications use PWM since a PWM generator can be designed relatively easily due to the availability of diverse semiconductor devices. Although PFM (VFM) is used for DC-DC converters, chargers, and other power supply applications, it is hardly ever used for motor applications. Some air conditioners use PAM control.

Table 4.1 summarizes the advantages and disadvantages of these three modulation techniques.

Table 4.1 Advantages and disadvantages of PWM, PFM, and PAM

Modulation Techniques	Advantages	Disadvantages	Application Examples
PWM	Filter design is easy, due to fixed switching frequency.	Switching loss generates even in light load by fixed frequency .	Many motors use PWM control. The spread of brushless motors enlarges market of the PWM control.
PFM	Efficiency improvement is possible because of decreasing switching frequency at light load.	Filter design is difficult, due to frequency modulation.	PFM is mainly used for power supply rather than inverter equipment. PFM improves efficiency at no load to light load.
PAM	Efficiency and a power factor are good at wide range loads.	Parts count of switching circuit such as booster increases.	In home appliances with widely ranged load such as air conditioner and refrigerator, there are some application examples to improve the issue of their power dissipation at low load.

4.3. Examples of PWM and PAM control circuits

Figure 4.2 shows examples of circuit block diagrams of PWM- and PAM-controlled inverter air conditioners. As described above, PWM varies the pulse width (i.e., duty cycle) to control the output while PAM varies the amplitudes (i.e., voltages) of pulses to control the output.

In the PWM controller of Figure 4.2, the partial-switching power factor correction (PFC) block increases a power factor and controls the harmonic current, and the voltage doubler rectifier converts 100 VAC into 240 VDC and passes it to the inverter. The inverter generates a waveform composed of many narrow pulses in each cycle and converts 240 VDC into AC. The width of switching pulses (i.e., the duty cycle) is varied in order to vary the average output voltage supplied to a motor. (The voltage doubler rectifier is provided to use the same inverter and compressor at 100 VAC and 200 VAC.)

The PAM controller shown in Figure 4.2 rectifies an AC voltage into a DC voltage. In order to control the output voltage supplied to a motor, the DC voltage fed to the inverter is varied by a voltage booster. To rotate a motor at low RPM, the DC voltage is set to a relatively low voltage (for example, at 150 V). When the motor rotates at high RPM, the DC voltage is boosted. In practice, many applications use PWM and PAM controllers in combination. PAM causes less switching loss than PWM.

PWM-controlled inverter air conditioner

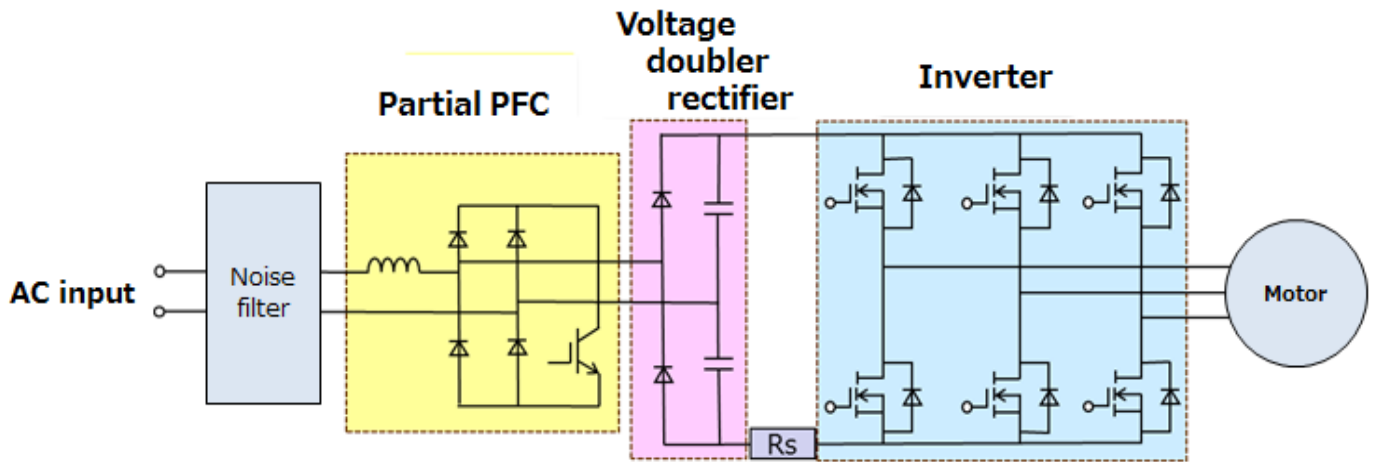

PAM-controlled inverter air conditioner

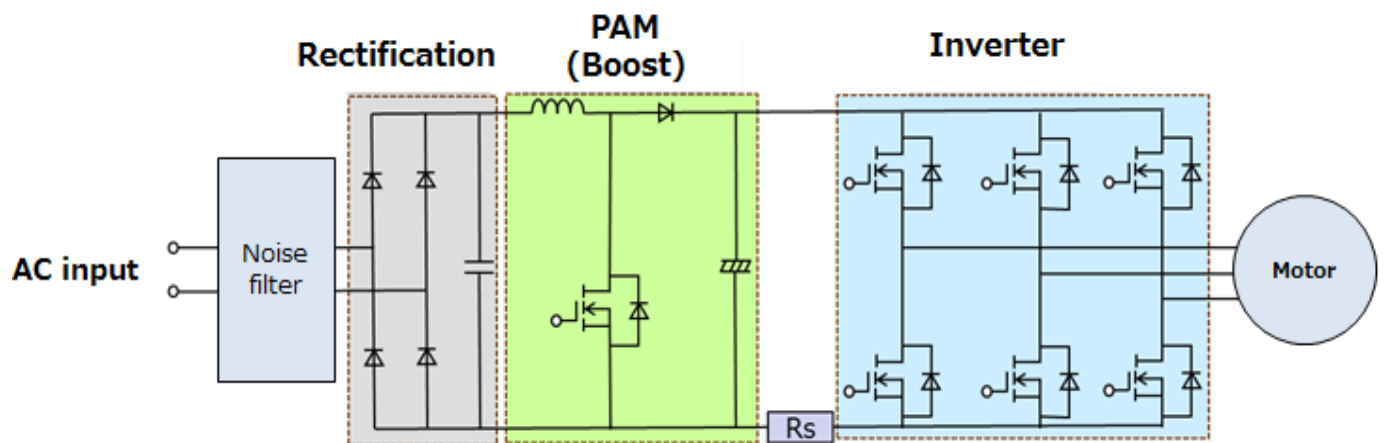

(Note: R_s : Shunt resistor for load current detection; voltage doubler rectifier used for a 100-VAC air conditioner)

Figure 4.2 Examples of circuit block diagrams of PWM- and PAM-controlled inverter air conditioners

5. 120° square-wave commutation vs. 180° sine-wave commutation

To control three-phase brushless DC (BLDC) motors, 120° and 180° commutation techniques are commonly used.

In comparison to 180° commutation, 120° commutation is easier to control as off-the-shelf controller ICs are commercially available. However, 120° commutation causes a motor to produce more acoustic noise and vibration and is less efficient than 180° commutation.

In other words, 180° commutation provides higher efficiency, quieter operation, and lower vibration than 120° commutation although 180° commutation requires more complicated control.

120° commutation

The 120° commutation technique is commonly used by BLDC motors. In Figure 5.1, the high-side device of one phase is on (120° period), the low-side device of the other phase is on (120° period), and in the remaining phase both the high-side and low-side devices are off (120° period) at any time.

In this switching scheme, each phase is connected to the power source for 120 electrical degrees, off for 60 electrical degrees, connected to GND for 120 electrical degrees and again off for 60 electrical degrees. It is thus called 120° commutation. Figure 5.2 illustrates the switching timing of each device.

Figure 5.3 shows the theoretical Phase-U and U-V phase-to-phase voltage waveforms. In case of the 120° commutation technique, since current flows through two resistive components (i.e., windings) at any one time, the phase voltage becomes $E/2$.

180° commutation

In 180° commutation, unlike 120° commutation, each phase is commutated at any time. It means either the high-side or low-side device of the same phase is on at any one time (Figure 5.2).

Therefore, in 180° commutation, the “on” states of the high-side and low-side devices overlap for a brief period while they are switching. This might create a potentially damaging condition called cross conduction in which the high-side and low-side devices provide a direct short-circuit across power supply and GND lines. To prevent cross conduction, an inverter driver provides a dead time of a few microseconds between switching transitions during which neither the high-side nor low-side device is on.

A high-side device of a given phase is on for 180 electrical degrees, and then the corresponding low-side device is on for the next 180 electrical degrees. This switching scheme is therefore called 180° commutation. Figure 5.3 shows the theoretical Phase-U and U-V phase-to-phase voltages for 180° commutation. During 180° commutation, the phase voltage becomes either $E/3$ or $2E/3$.

Although the above paragraphs state that a device remains on during its “on” period, a PWM control signal is applied to the “on” device in most cases. There are various control methods for applying a PWM signal. For 120° commutation, either the high-side or low-side device is PWM-controlled. There are two options for the 180° commutation scheme. While either the high-side or low-side device is on (with PWM control), one of the options keeps the other-side device continuously off in this period.

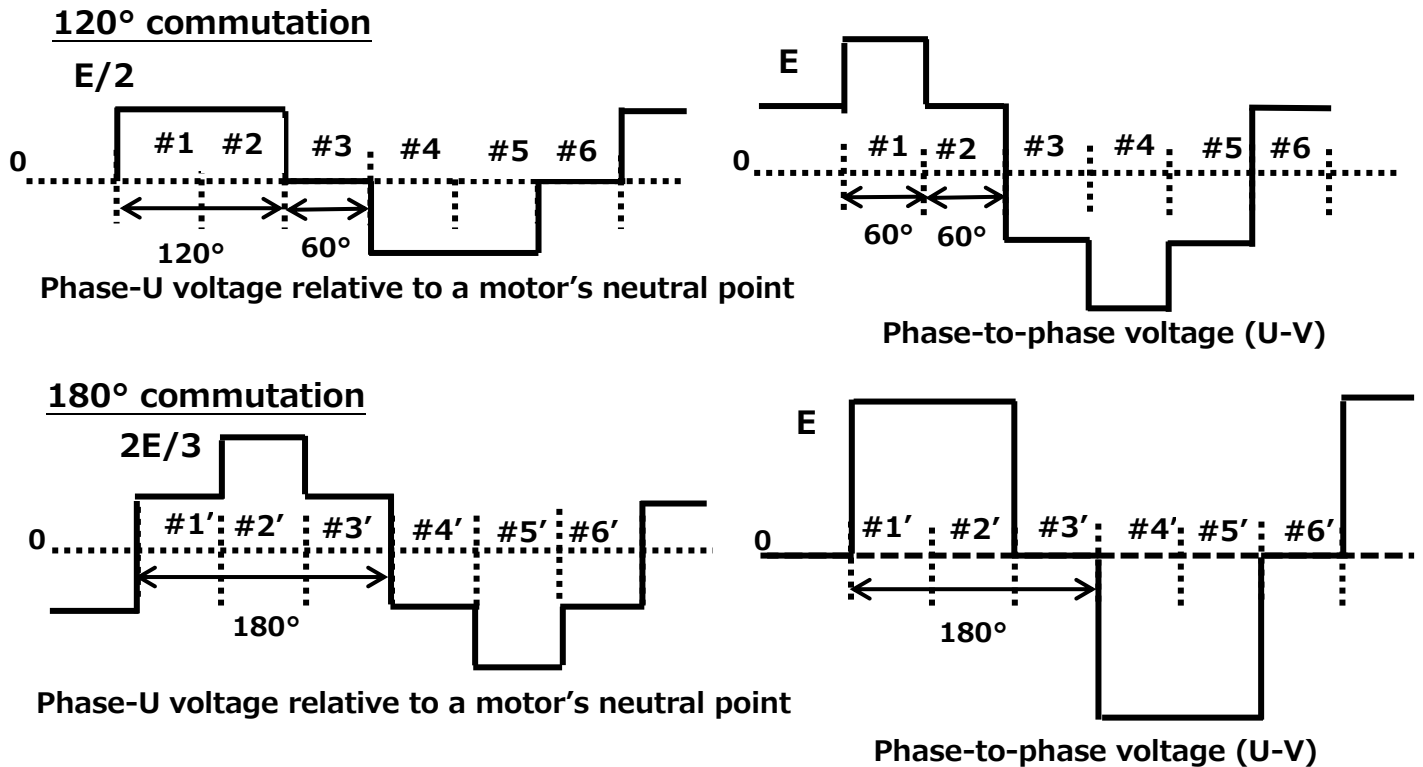

Figure 5.3 Theoretical phase-to-phase voltage waveforms for 120° and 180° commutation

6. Two-phase and three-phase PWM modulation

PWM varies the width of pulses required for the switching of transistors in an inverter in order to generate an output waveform composed of many narrow pulses in each cycle. As a result, the average voltage of the modulated output pulses becomes sinusoidal.

To generate a PWM signal, a signal (sine wave) is compared with a carrier waveform (triangle). When the signal is greater than the triangle waveform, the PWM signal is high and switches on a transistor.

As a result of this switching scheme, the average value of the output phase-to-phase voltages becomes sinusoidal. This way, an inverter regulates voltage.

Three-phase modulation modulates all of the three phases of a three-phase inverter simultaneously (to generate a sinusoidal PWM signal) whereas two-phase modulation modulates two of the three phases at any one time while holding the other phase at High or Low level.

Compared to three-phase modulation, two-phase modulation suffers less loss because of fewer switching actions, but provides less control flexibility. Another disadvantage of two-phase modulation is that a zero-phase voltage (i.e., the voltage at the midpoint between the neutral point of a load and the neutral point of a converter) fluctuates significantly at a low output amplitude. Generally, an advantage of two-phase modulation is its ability to make the maximum output phase-to-phase voltage equal to the input DC voltage.

6.1. Three-phase PWM modulation

Figure 6.1 shows the circuit diagram of a three-phase inverter for typical three-phase modulation. Let the PWM output voltages for Phase U, Phase V, and Phase W be V_U , V_V , and V_W respectively and the phase-to-phase voltages be V_{U-V} , V_{V-W} , and V_{W-U} .

1. The three-phase AC waveform is a reference sine-wave signal that synchronizes with the rotation speed of a motor, and a triangle signal acts as a carrier that determines the switching frequency. The sine-wave signal is compared with the triangle waveform. When the value of the signal is greater than that of the triangle waveform, a high-side transistor turns on. The V_U , V_V , and V_W voltages are in the High state when the corresponding high-side transistors are on (Figure 6.2). The inverse values of the high-side signals are applied to the low-side transistors.
2. The motor supply voltages are equal to the differences among the phase input voltages (V_U , V_V , and V_W). Figure 6.3 shows the changes in motor supply voltages. The phase-to-phase voltages (V_{U-V} , V_{V-W} , and V_{W-U}), which have the same frequency as the reference sine-wave signal, are applied to a motor.
3. The motor supply voltages can be controlled by varying the voltages of the reference three-phase AC waveform and the triangle waveform.

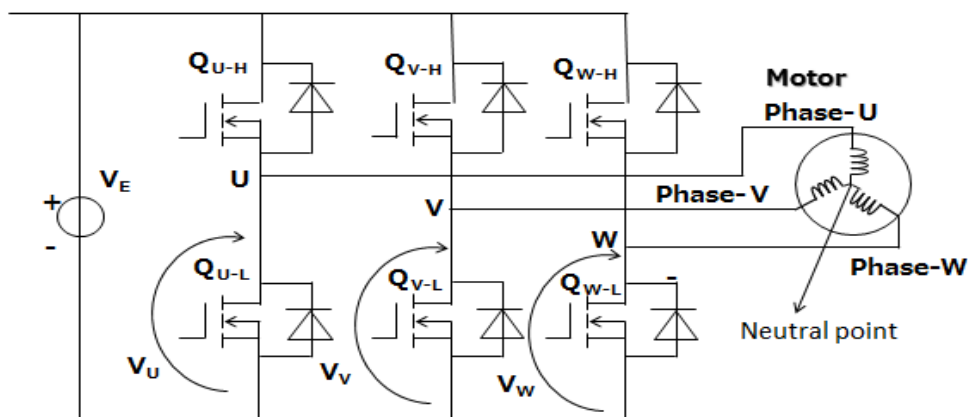

Figure 6.1 Phase voltages in a three-phase inverter

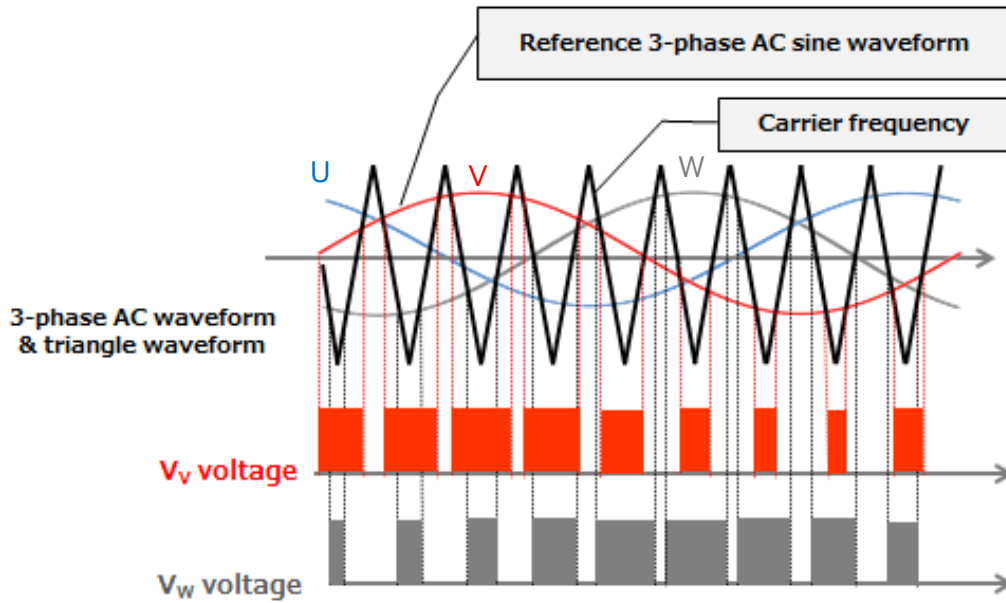

Figure 6.2 PWM signal generation (sine-triangle pulse-width modulation)

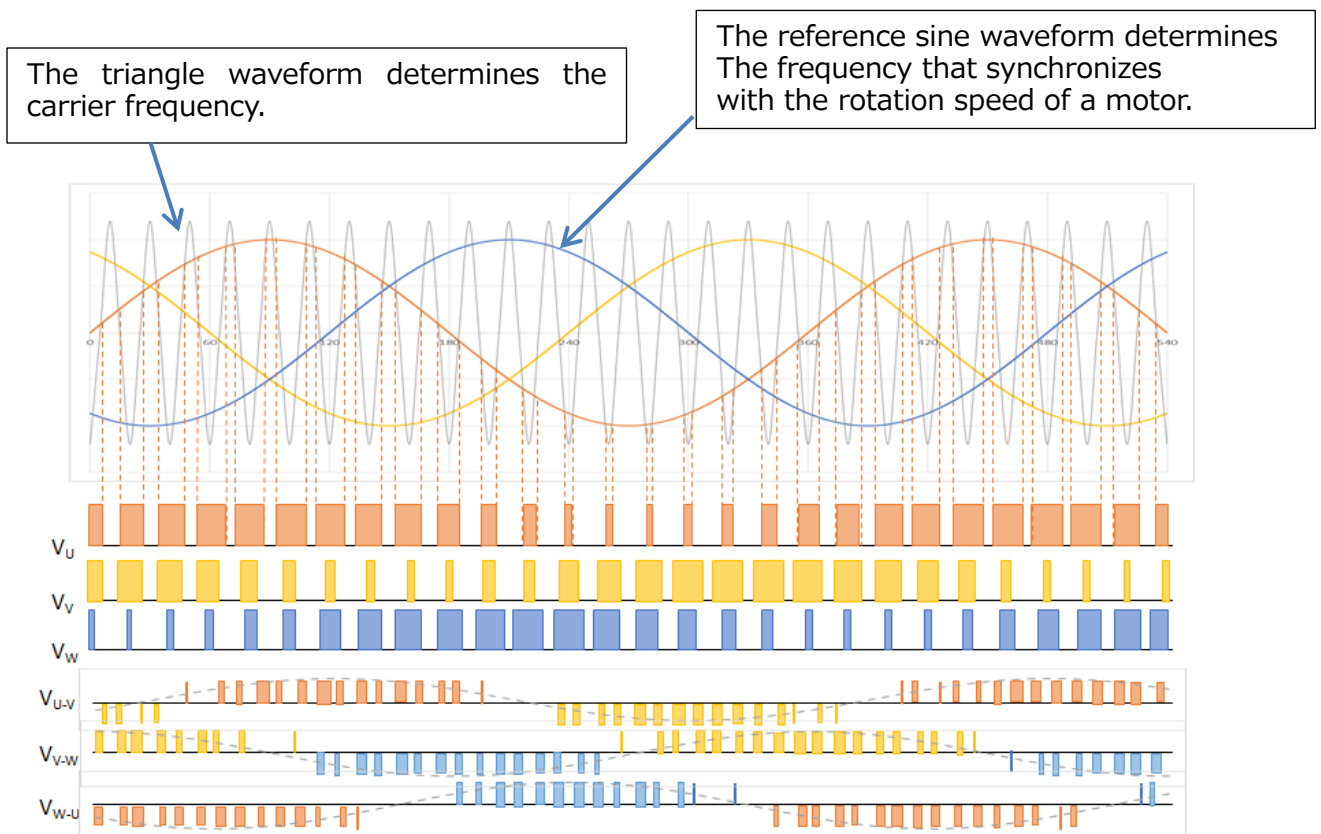

Figure 6.3 Example of PWM signal generation

6.2. Two-phase PWM modulation

As described above, a signal is compared with a triangle carrier. The two-phase PWM modulation scheme modulates two of the three phases at any one time while holding the other phase High or Low.

The two-phase modulation scheme has two-thirds of the switching actions of the three-phase modulation scheme and therefore suffers less switching loss. Other advantages of two-phase modulation include a higher maximum phase-to-phase voltage (i.e., voltage utilization rate). (However, there is a way to control the maximum phase-to-phase voltage for three-phase modulation.)

The following subsections describe typical two-phase modulation methods.

6.2.1. Control using both the upper and lower arms

Figure 6.4 shows a configuration of the power section of a typical voltage-type PWM inverter. Figure 6.5 shows its input voltage signals to U, V, and W.

Let the ratio of the voltage setpoint to the DC supply voltage be a . Then, changes of the Phase-U input signal $v(\theta)$ in a cycle can be represented as shown in Table 6.1. The Phase-V and Phase-W input waveforms lag behind Phase U by 120° and 240° respectively. The output of each phase keeps High for 60 electrical degrees and Low for 60 electrical degrees without modulation. This means two phases are modulated at any one time while the other one is held either High or Low.

As described above, this helps reduce switching loss and increases the maximum phase-to-phase voltage (i.e., voltage utilization rate).

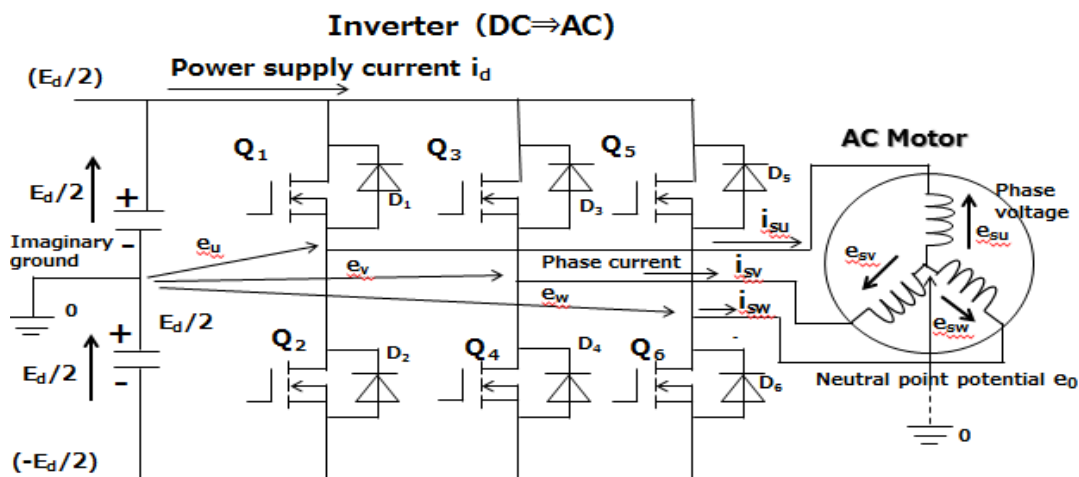

Figure 6.4 Three-phase inverter

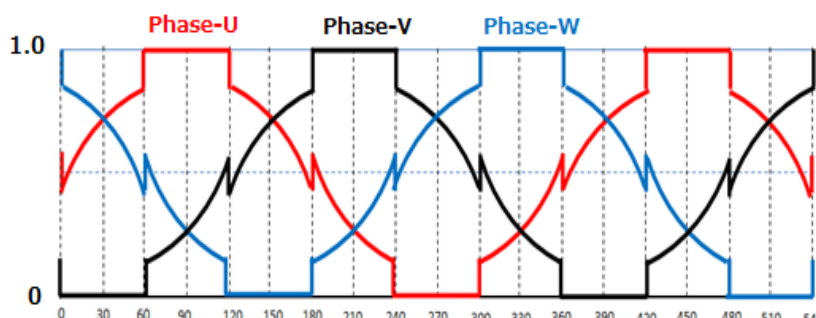

Figure 6.5 Input voltage waveforms for two-phase modulation
(Control using both the upper and lower arms)

Table 6.1 Input voltage signals

θ [deg]	Input Signal v
0° to 60°	$a \sin(\theta+30^\circ)$
60° to 120°	1.0
120° to 180°	$a \sin(\theta-30^\circ)$
180° to 240°	$1.0+a \sin(\theta+30^\circ)$
240° to 300°	0
300° to 360°	$1.0+a \sin(\theta-30^\circ)$

6.2.2. Control using only the lower arm

Of the three-phase waveforms, the lower-arm power device of the phase with the lowest voltage setpoint is kept "on" for 120 electrical degrees by this technique while the other two phases are modulated. Figure 6.6 shows the waveforms. As described above, this helps reduce switching loss and increases the maximum phase-to-phase voltage (i.e., voltage utilization rate). The maximum voltage at a motor's neutral point during this modulation sequence is two-thirds that of a typical three-phase modulation (sine-triangle PWM) and therefore improves the motor reliability. The following describes the neutral-point voltage.

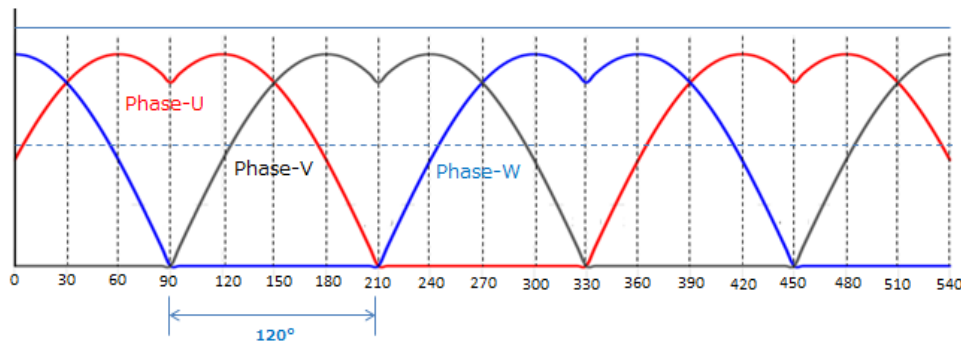

**Figure 6.6 Two-phase modulation voltage waveforms
(Control using only the lower arm)**

Neutral-point voltage

The switching of a voltage-type PWM inverter generates a neutral-point voltage, which is divided by the capacitance distributed in a motor and appears as a motor shaft voltage. The shaft voltage damages the surfaces of a motor's metal bearings and adversely affects its quietness and service life.

Let a motor's neutral-point voltage be e_0 . Then, the phase voltages of the motor (e_{su} , e_{sv} , and e_{sw}) shown in Figure 6.4 have the following relationships:

$$e_{su} = e_u - e_0, e_{sv} = e_v - e_0, e_{sw} = e_w - e_0$$

Due to the intrinsic characteristics of the motor, $e_{su} + e_{sv} + e_{sw} = 0$. Therefore, the neutral-point voltage (e_0) of the motor windings is expressed as:

$$e_0 = (e_u + e_v + e_w)/3$$

The voltage at the neutral point of the motor windings is also represented by the following equations:

1. When e_u , e_v , and e_w are all High: $e_0 = (e_u + e_v + e_w)/3 = (1/2 E_d \times 3)/3 = E_d/2$
2. When two phases are High and one phase is Low: $e_0 = (E_d/2 \times 2 + (-E_d/2))/3 = E_d/6$
3. When one phase is High and two phases are Low: $e_0 = (E_d/2 + (-E_d/2) \times 2)/3 = -E_d/6$
4. When e_u , e_v , and e_w are all Low: $e_0 = (-E_d/2 \times 3)/3 = -E_d/2$

Hence, the neutral-point voltage changes, taking two-level values between $-E_d/2$ or $+E_d/2$.

Consequently, voltages different from the mains supply voltage are applied to the neutral point.

Figure 6.7 shows the neutral-point voltage during three-phase modulation.

In two-phase modulation (controlled lower arm type), one of the three phases is Low level at any one time. Therefore, an inverter does not go into state #1 shown above. As a result, a motor's neutral-point voltage changes between $-E_d/2$ and $+E_d/6$, with two-thirds of the voltage swing of three-phase modulation. Figure 6.8 shows the neutral-point voltage during two-phase modulation.

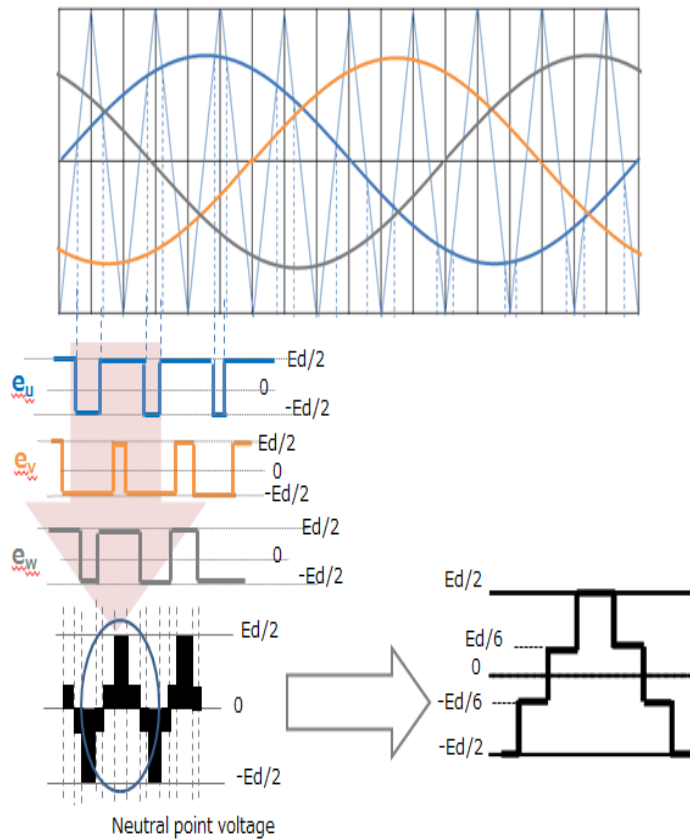

Figure 6.7 Neutral-point voltage during three-phase modulation

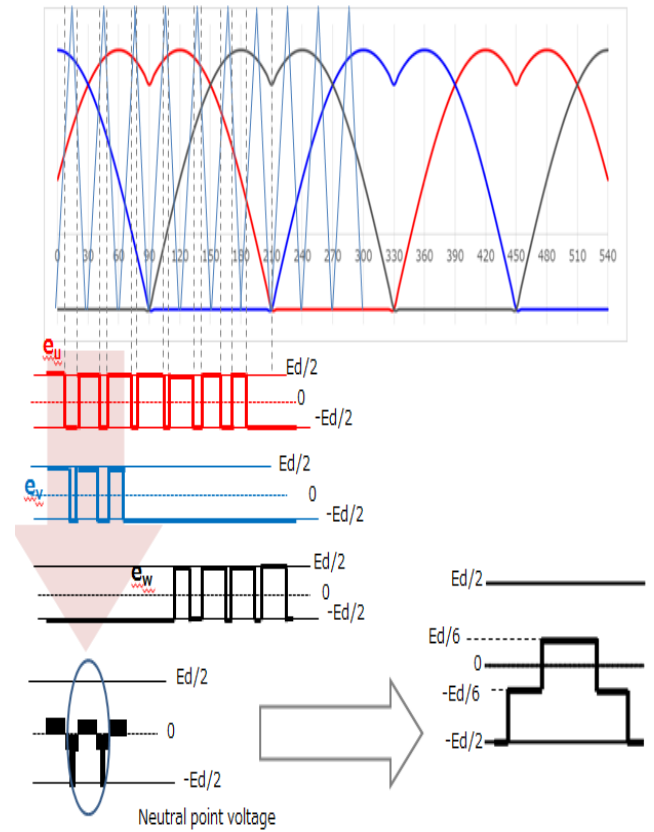

Figure 6.8 Neutral-point voltage during two-phase modulation

7. Miscellaneous information

7.1. Multilevel inverters

While the output voltage of a two-level PWM inverter takes either the zero or High level, three-level and multilevel PWM inverters provide the output voltage at multiple levels by dividing the input DC voltage.

7.1.1. Three-level PWM

Table 7.1 compares two- and three-level inverters.

Table 7.1 Comparisons of two- and three-level inverter circuits and their output voltage waveforms

	Two-Level	Three-Level	
		Neutral-Point Clamped	Bidirectional Switch
Circuit			
Output phase-to-phase Voltage Waveform			

The phase-to-phase output voltage of a two-level inverter has a PWM waveform with two values ($+V_{DD}$ and $-V_{DD}$) symmetrical around zero. The PWM waveform from a three-level inverter is also symmetrical around zero, but takes values of $\pm V_{DD}$ and $\pm V_{DD}/2$.

An advantage of a three-level inverter is an output waveform closer to a sine wave. This helps reduce the size of an LC filter used to smooth the output waveform into a sine wave. In addition, since the output voltage swing of a three-level inverter is half that of a two-level inverter per switching action, the three-level inverter has less switching loss and helps reduce the noise generated by a motor system. Therefore, three-level inverters are suitable for reducing the size and improving the efficiency of motor applications.

7.1.2. More on three-level PWM

Figure 7.1 shows examples of typical three-level PWM inverters. There are two types of three-level PWM inverters: neutral-point-clamped (NPC) inverters (a) and bidirectional-switch inverters (b).

(a) NPC inverters: Diodes^{*1} are used to clamp the voltage at the midpoint of V_{DD} on the input side. Since the high side and the low side each consist of two transistors per phase, transistors with half breakdown voltage can be used in NPC inverters. In addition, due to a lower switching voltage, NPC inverters have less switching loss. A downside is that NPC inverters tend to have larger conduction loss due to the presence of two transistors in the current path.

(b) Bidirectional-switch inverters: The midpoint of V_{DD} is connected with bidirectional switches. Bidirectional switches can be configured by connecting power MOS pairs in anti-series as shown in (b) or two reverse-blocking IGBTs in parallel. Since transistors in the three-phase bridge need to have a breakdown voltage higher than V_{DD} , using power MOS transistors might not provide a significant benefit.

***1 Power MOSFETs are used in some cases.**

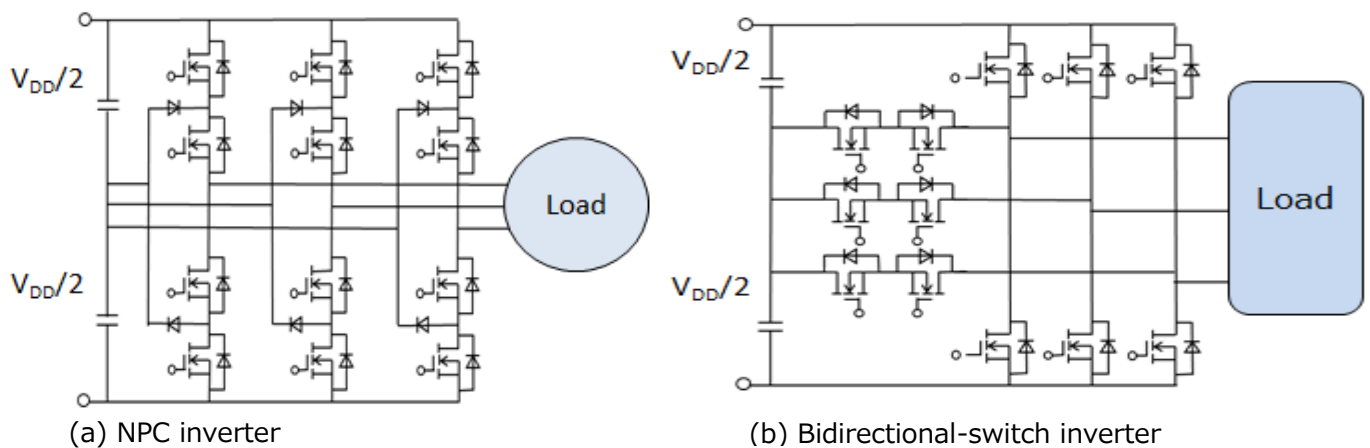

Figure 7.1 Three-level inverter control

Figure 7.2 shows the voltage waveforms for three-level inverter control.

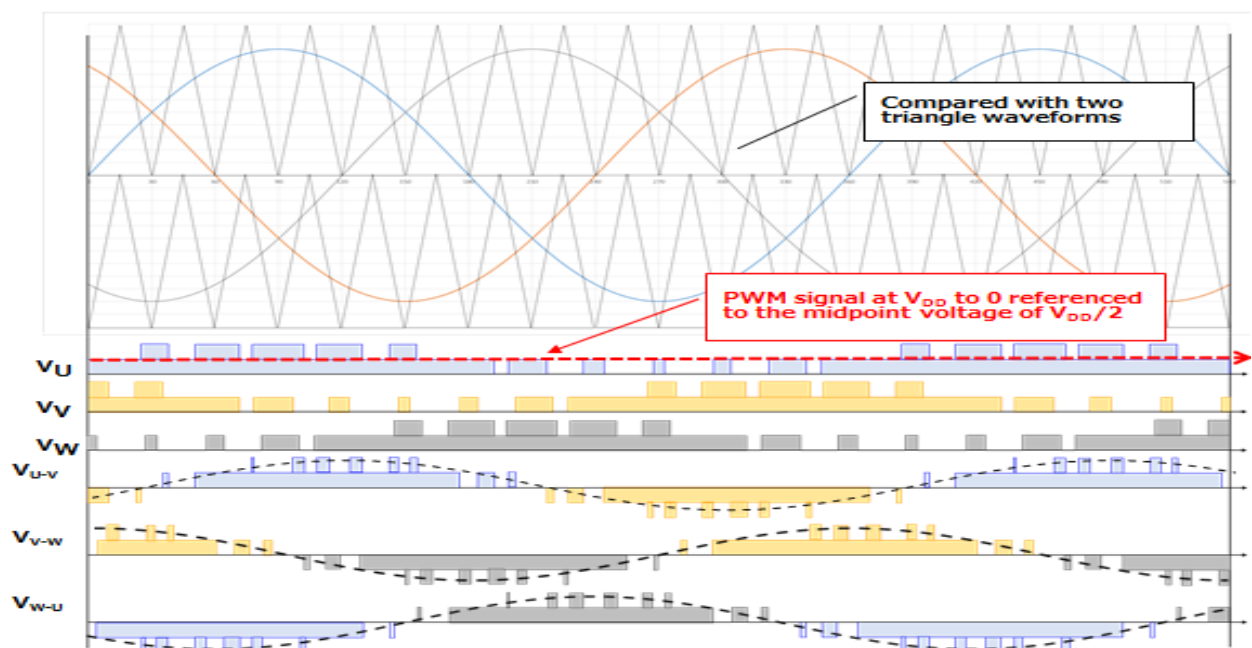

Figure 7.2 Signals generated by a three-level inverter

7.2. Gate-drive power supplies (for three-phase inverters)

Generally, a three-phase inverter needs four independent (isolated) power supplies for transistor gate drive: three for the high side and one for the low side.

Many inverters are designed to use four independent external power supplies. There are also many inverters that incorporate an auxiliary circuit for generating high-side supply voltages and use an external power supply only for the low side.

High-side power supplies can be divided into two types: 1) a bootstrap power supply that uses the switching of the main inverter and 2) a charge pump that uses the switching of a driver or a control circuit independent of the main inverter. In either case, the main inverter needs to raise the high-side supply voltage sufficiently prior to operation. The power supply capacitor in the high side must have a value much higher than the input capacitance of switching devices.

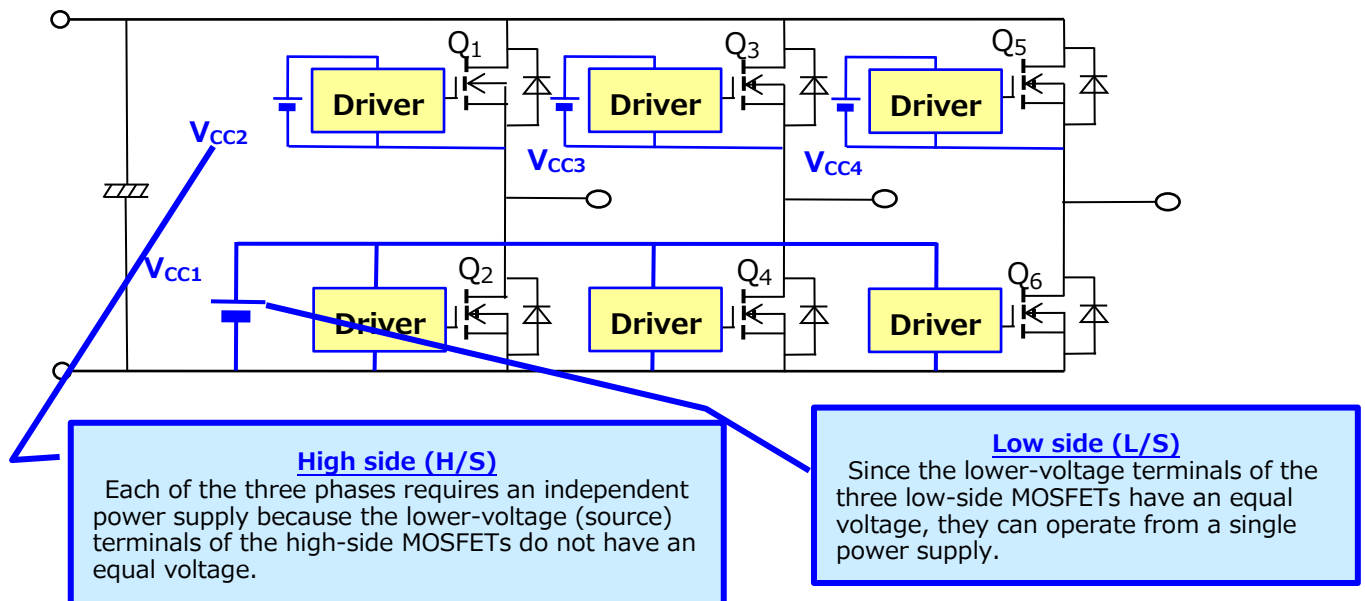

Figure 7.3 Gate driver power supplies for a three-phase inverter

7.2.1. Charge pump

In Figure 7.4, the NMOS and PMOS transistors operate with mutually exclusive logic signals. #1) While the NMOS transistor is on, C_1 is charged through the V_{CCL} - D_1 - C_1 -NMOS loop. #2) This turns on the PMOS transistor, causing V_{CCH} to be formed through the C_1 - D_2 - V_{CCH} -PMOS- C_1 loop.

V_{CCH} is placed in such a manner as to be superimposed on the main power supply (V_{DD}). Gate driver circuits are configured via a freewheeling diode (FWD) of the main switching transistors. Since the drain of the high-side MOSFET acts as a reference (on the lower-voltage side) for V_{CCH} , the high side of a charge pump can also operate from a single power supply. In practice, however, charge pumps are not used for high-voltage applications since many of the devices including the PMOS and NMOS transistors need a breakdown voltage higher than $V_{DD}+V_{CCH}$.

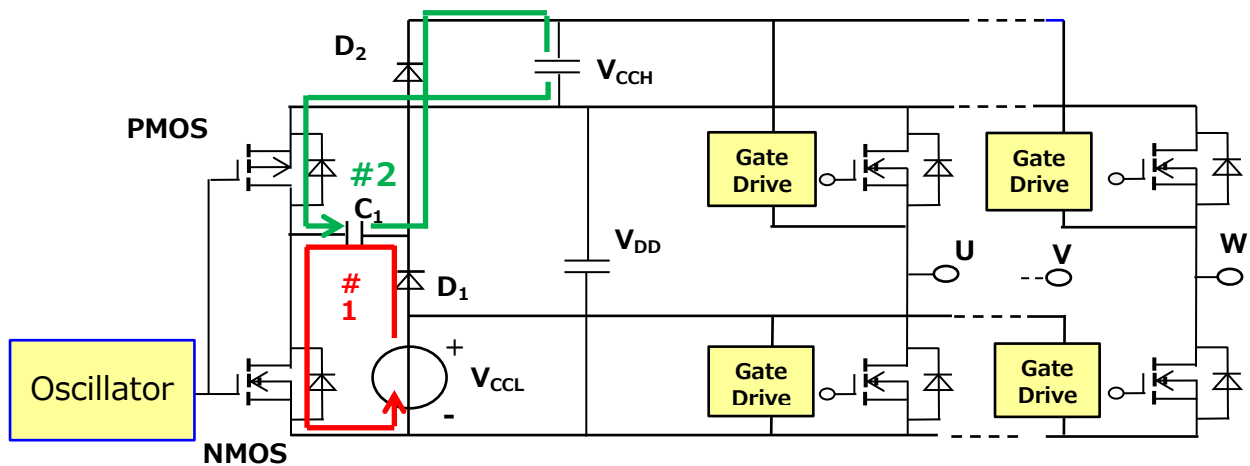

Figure 7.4 Charge pump circuit

7.2.2. Bootstrap circuit

In Figure 7.5, the power supplies for the high-side gate drivers are primarily formed by the loops $V_{CC} \rightarrow (\text{resistor}) \rightarrow D \rightarrow C_1$ (or C_2 or C_3) $\rightarrow Q_2$ (or Q_4 or Q_6) $\rightarrow V_{CC}$. The midpoint voltage of each phase needs to be equal to the lower-side voltage of V_{CC} in order for C_1 to C_3 to be charged. This means C_1 , C_2 , and C_3 are charged while Q_2 , Q_4 , and Q_6 are on or while currents are flowing back through the FWDs. The charge voltages might decrease significantly, depending on the high-side and low-side on-off timings and the ratios of C_1 to C_3 to the input capacitances of the corresponding MOSFETs.

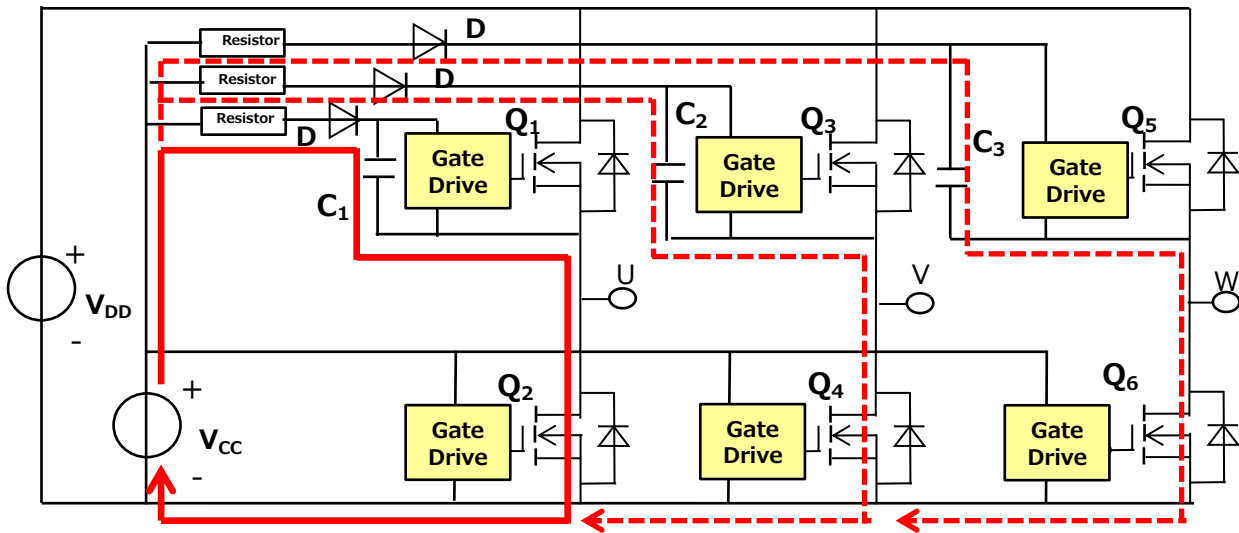

Figure 7.5 Bootstrap circuit

7.3. Power losses (Three-phase modulation)

Figure 7.6 shows a basic three-phase inverter. The power losses of an inverter consist of IGBT conduction loss P_{cond} , FWD conduction loss P_F , IGBT turn-on switching loss P_{on} , IGBT turn-off switching loss P_{off} , FWD reverse recovery loss P_{rr} , and so on. (The IGBT drive loss P_{drive} and the IGBT output capacitance loss P_{oss} are negligibly small.) Figure 7.7 shows typical current and voltage waveforms of a three-phase inverter and its operating locus.

The total loss P_{ttl} of each device is calculated as follows (in watts):

$$P_{ttl} = P_{cond} + P_F + P_{on} + P_{off} + P_{rr}$$

- P_{cond} : IGBT conduction loss
- P_F : FWD freewheeling conduction loss
- P_{on} : IGBT turn-on switching loss
- P_{off} : IGBT turn-off switching loss
- P_{rr} : FWD reverse recovery loss

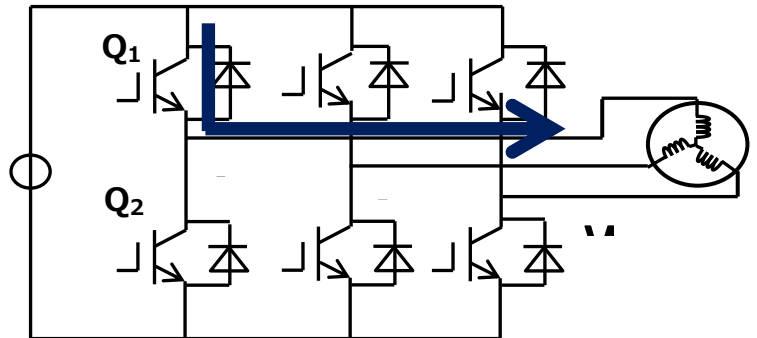
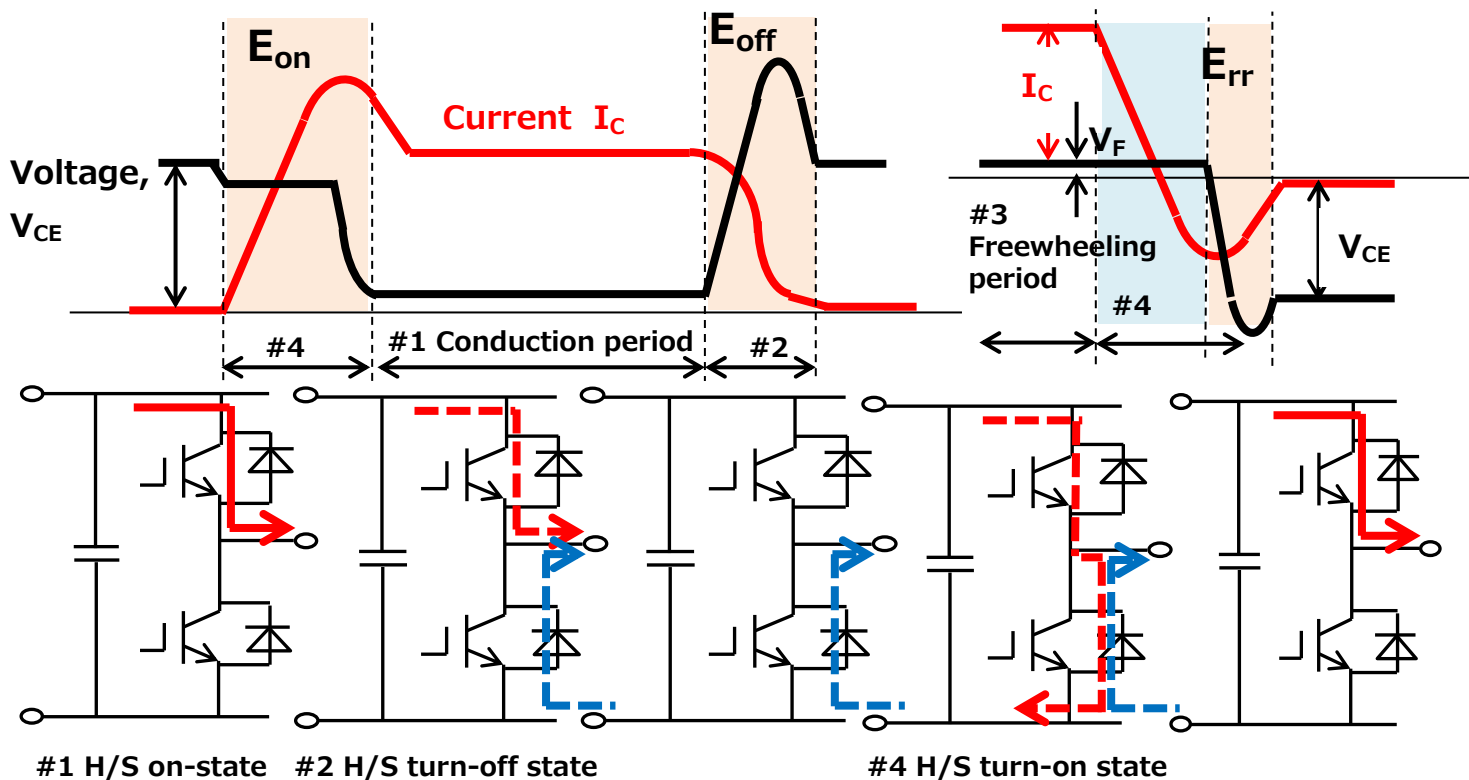

Figure 7.6 Three-phase inverter circuit



Note: E_{on} is a turn-on loss per pulse, E_{off} is a turn-off loss per pulse, and E_{rr} is a reverse recovery loss of an FWD per pulse.

Figure 7.7 IGBT switching waveforms and inverter operation

7.3.1. Calculating the IGBT conduction loss P_{cond}

The duty cycle D of a pulse of a PWM signal is calculated as follows ($D=1$ when $D \geq 1$):

$$D = (1 + a \times \sin(\theta - \varphi)) / 2$$

a : Modulation index, which is typically equal to or less than 1, but is equal to or greater than 1 for two-phase modulation

φ : Phase delay. Generally, a power factor is represented as $\cos\varphi$.

θ : Electrical angle (sine-wave phase)

Sine-wave signals flow through each phase of an inverter. The IGBT collector current I_C is calculated as: $I_C = I_{CP} \times \sin\theta$. The collector-emitter saturation voltage, $V_{CE(sat)}$, represents a collector-emitter voltage at the peak collector current I_{CP} . When the collector-emitter saturation voltage is linearly approximated in proportion to the collector current I_C , it is expressed as $V_{CE(sat)} \times \sin\theta$.

Therefore, the MOSFET conduction loss is calculated by 1) multiplying a phase current by $V_{CE(sat)} \times \sin\theta$ at high temperature, 2) integrating the result of 1) over a phase period of $0 \sim 180^\circ$ (π), and then 3) dividing the result of 2) by a cycle:

$$\begin{aligned} P_{cond} &= \frac{1}{2\pi} \int_0^\pi (I_{CP} \times \sin\theta \times V_{CE(sat)} \times \sin\theta \times D) d\theta \\ &= \frac{1}{2\pi} \int_0^\pi (I_{CP} \times \sin\theta \times V_{CE(sat)} \times \sin\theta \times \frac{1}{2}(1 + a \times \sin(\theta - \varphi))) d\theta \\ &= I_{CP} \times V_{CE(sat)} \left(\frac{1}{8} + \frac{a}{3\pi} \times \cos\varphi \right) \end{aligned}$$

7.3.2. Calculating the FWD conduction loss P_F

The duty cycle D of a pulse of a PWM signal is calculated as follows ($D=0$ when $D \leq 0$):

$$D = (1 - a \times \sin(\theta - \varphi)) / 2$$

The phase freewheeling current I_F is calculated as: $I_F = I_{FP} \times \sin\theta$. V_F represents a voltage at the peak freewheeling current I_{FP} . When the FWD forward voltage is linearly approximated in proportion to the forward current I_F , it is expressed as $V_F \times \sin\theta$. (More accurate approximation is preferable.)

Therefore, the FWD conduction loss is calculated by 1) multiplying a phase freewheeling current by $V_F \times \sin\theta$, 2) integrating the result of 1) over a phase period of 0 to 180° (π), and then 3) dividing the result of 2) by a cycle:

$$\begin{aligned} P_F &= \frac{1}{2\pi} \int_0^\pi (I_{FP} \times \sin\theta \times V_F \times \sin\theta \times D) d\theta \\ &= \frac{1}{2\pi} \int_0^\pi (I_{FP} \times \sin\theta \times V_F \times \sin\theta \times \frac{1}{2}(1 - a \times \sin(\theta - \varphi))) d\theta \\ &= I_{FP} \times V_F \left(\frac{1}{8} - \frac{a}{3\pi} \times \cos\varphi \right) \end{aligned}$$

When an FWD is in a freewheel mode (i.e., a current is flowing back through the FWD), no current flows through the associated parallel IGBT even if an “on” signal is applied to the IGBT. However, when a MOSFET is used as a switching device instead of an IGBT, a current flows in the reverse (negative) direction through the MOSFET when it turns on while the associated FWD is in a freewheel mode. It is therefore necessary to take the loss of MOSFET into consideration when calculating the loss in freewheel mode.

7.3.3. Calculating the turn-on and turn-off losses (P_{on} and P_{off}) of an IGBT

This subsection describes how to calculate the turn-on and turn-off losses (P_{on} and P_{off}) of an IGBT caused by PWM switching operation.

Switching energy loss can be approximated in various ways. The following shows two examples.

(1) Using average current

Let the RMS value of the phase output current of an inverter be I_O . Then, the peak current is $\sqrt{2} \cdot I_O$. At this time, the average current I_{AV} of a sine wave is calculated as follows. (The average of a sine wave is **peak $\times 2/\pi$** .)

$$I_{AV} = 2/\pi \times \sqrt{2} \cdot I_O$$

Let the turn-on and turn-off losses of a pulse be E_{onAV} and E_{offAV} respectively at I_{AV} and the carrier frequency be f_c . Then, since each of the high-side and low-side devices conducts current during a half-wave period, the turn-on and turn-off losses (P_{on} and P_{off}) are calculated as follows, where E_{onAV} and E_{offAV} must be measured.

$$P_{on} = E_{onAV} \times f_c / 2$$

$$P_{off} = E_{offAV} \times f_c / 2$$

(2) Using peak current

Again, it is assumed that each of the high-side and low-side devices conducts current during a half-wave period. Let the turn-on and turn-off losses of a pulse be E_{onM} and E_{offM} respectively at the peak value of a sine-wave current I_P and assume that the losses increase in proportion to a current. Also, let the carrier frequency be f_c . Then,

$$\begin{aligned} P_{on} &= \frac{1}{2\pi} \int_0^\pi E_{onM} \times \sin\theta d\theta \times f_c \\ &= \frac{1}{2\pi} E_{onM} \times [-\cos\theta]_0^\pi \times f_c \\ &= \frac{1}{2\pi} E_{onM} \times 2 \times f_c \\ &= \frac{1}{\pi} E_{onM} \times f_c \end{aligned}$$

Likewise, P_{off} can be calculated as:

$$P_{off} = \frac{1}{\pi} E_{offM} \times f_c$$

Since the average value of E_{onM} is $E_{onAV} = E_{onM} \times 2/\pi$, the results of the equations shown in (1) and (2) are equal.

7.3.4. Calculating the FWD reverse recovery loss P_{trr}

When considered in the same manner as for IGBT switching losses, the reverse recovery loss P_{trr} of an FWD can be expressed as:

$$P_{trr} = E_{rrAV} \times f_c / 2 \quad \text{or} \quad P_{trr} = E_{rrM} \times f_c \times 1/n$$

where E_{rrAV} is the average reverse recovery loss per pulse, and E_{rrM} is the maximum reverse recovery loss per pulse.

P_{trr} can also be calculated from the reverse recovery waveform shown in Figure 7.8

It is more practical to measure $t_{rr(2)}$ and use it in calculation instead of t_{rr} .

As shown in Figure 7.8, the reverse recovery loss P_{trr} of an FWD occurs when its reverse recovery current and voltage waveforms overlap. Considering the average values of I_{rr} and t_{rr} (I_{rrAV} and t_{rrAV}), E_{trrAV}

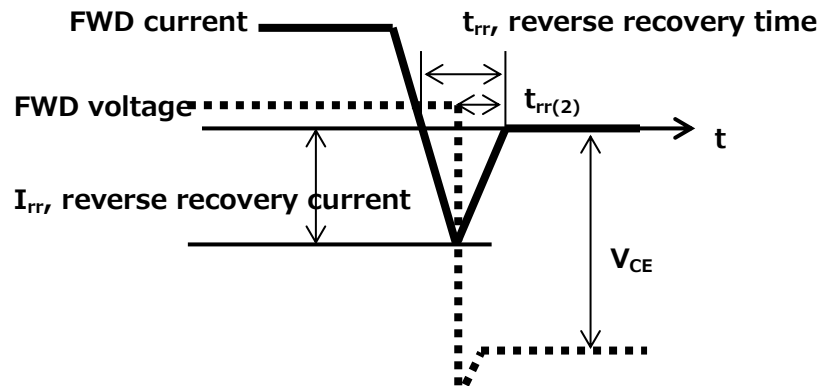

Figure 7.8 FWD reverse recovery waveform

can be calculated as follows since an FWD is in reverse recovery during the latter half of the output current cycle.

$$E_{trrAV} = (I_{rrAV} \times V_{CE} \times t_{trrAV}) / 4$$

where E_{trrAV} is the average reverse recovery loss per pulse.

$$P_{trr} = (I_{rrAV} \times V_{CE} \times t_{trrAV}) / 4 \times f_c \times 1/2$$

$$= 1/8 \times I_{rrAV} \times V_{CE} \times t_{trrAV} \times f_c \quad \text{or} \quad 1/4 \times I_{rrAV} \times V_{CE} \times t_{trr(2)AV} \times f_c \quad (t_{trr(2)AV} = t_{trrAV} / 2)$$

RESTRICTIONS ON PRODUCT USE

Toshiba Corporation and its subsidiaries and affiliates are collectively referred to as "TOSHIBA". Hardware, software and systems described in this document are collectively referred to as "Product".

- TOSHIBA reserves the right to make changes to the information in this document and related Product without notice.
- This document and any information herein may not be reproduced without prior written permission from TOSHIBA. Even with TOSHIBA's written permission, reproduction is permissible only if reproduction is without alteration/omission.
- Though TOSHIBA works continually to improve Product's quality and reliability, Product can malfunction or fail. Customers are responsible for complying with safety standards and for providing adequate designs and safeguards for their hardware, software and systems which minimize risk and avoid situations in which a malfunction or failure of Product could cause loss of human life, bodily injury or damage to property, including data loss or corruption. Before customers use the Product, create designs including the Product, or incorporate the Product into their own applications, customers must also refer to and comply with (a) the latest versions of all relevant TOSHIBA information, including without limitation, this document, the specifications, the data sheets and application notes for Product and the precautions and conditions set forth in the "TOSHIBA Semiconductor Reliability Handbook" and (b) the instructions for the application with which the Product will be used with or for. Customers are solely responsible for all aspects of their own product design or applications, including but not limited to (a) determining the appropriateness of the use of this Product in such design or applications; (b) evaluating and determining the applicability of any information contained in this document, or in charts, diagrams, programs, algorithms, sample application circuits, or any other referenced documents; and (c) validating all operating parameters for such designs and applications. **TOSHIBA ASSUMES NO LIABILITY FOR CUSTOMERS' PRODUCT DESIGN OR APPLICATIONS.**
- **PRODUCT IS NEITHER INTENDED NOR WARRANTED FOR USE IN EQUIPMENTS OR SYSTEMS THAT REQUIRE EXTRAORDINARILY HIGH LEVELS OF QUALITY AND/OR RELIABILITY, AND/OR A MALFUNCTION OR FAILURE OF WHICH MAY CAUSE LOSS OF HUMAN LIFE, BODILY INJURY, SERIOUS PROPERTY DAMAGE AND/OR SERIOUS PUBLIC IMPACT ("UNINTENDED USE").** Except for specific applications as expressly stated in this document, Unintended Use includes, without limitation, equipment used in nuclear facilities, equipment used in the aerospace industry, medical equipment, equipment used for automobiles, trains, ships and other transportation, traffic signaling equipment, equipment used to control combustions or explosions, safety devices, elevators and escalators, devices related to electric power, and equipment used in finance-related fields. **IF YOU USE PRODUCT FOR UNINTENDED USE, TOSHIBA ASSUMES NO LIABILITY FOR PRODUCT.** For details, please contact your TOSHIBA sales representative.
- Do not disassemble, analyze, reverse-engineer, alter, modify, translate or copy Product, whether in whole or in part.
- Product shall not be used for or incorporated into any products or systems whose manufacture, use, or sale is prohibited under any applicable laws or regulations.
- The information contained herein is presented only as guidance for Product use. No responsibility is assumed by TOSHIBA for any infringement of patents or any other intellectual property rights of third parties that may result from the use of Product. No license to any intellectual property right is granted by this document, whether express or implied, by estoppel or otherwise.
- **ABSENT A WRITTEN SIGNED AGREEMENT, EXCEPT AS PROVIDED IN THE RELEVANT TERMS AND CONDITIONS OF SALE FOR PRODUCT, AND TO THE MAXIMUM EXTENT ALLOWABLE BY LAW, TOSHIBA (1) ASSUMES NO LIABILITY WHATSOEVER, INCLUDING WITHOUT LIMITATION, INDIRECT, CONSEQUENTIAL, SPECIAL, OR INCIDENTAL DAMAGES OR LOSS, INCLUDING WITHOUT LIMITATION, LOSS OF PROFITS, LOSS OF OPPORTUNITIES, BUSINESS INTERRUPTION AND LOSS OF DATA, AND (2) DISCLAIMS ANY AND ALL EXPRESS OR IMPLIED WARRANTIES AND CONDITIONS RELATED TO SALE, USE OF PRODUCT, OR INFORMATION, INCLUDING WARRANTIES OR CONDITIONS OF MERCHANTABILITY, FITNESS FOR A PARTICULAR PURPOSE, ACCURACY OF INFORMATION, OR NONINFRINGEMENT.**
- Do not use or otherwise make available Product or related software or technology for any military purposes, including without limitation, for the design, development, use, stockpiling or manufacturing of nuclear, chemical, or biological weapons or missile technology products (mass destruction weapons). Product and related software and technology may be controlled under the applicable export laws and regulations including, without limitation, the Japanese Foreign Exchange and Foreign Trade Law and the U.S. Export Administration Regulations. Export and re-export of Product or related software or technology are strictly prohibited except in compliance with all applicable export laws and regulations.
- Please contact your TOSHIBA sales representative for details as to environmental matters such as the RoHS compatibility of Product. Please use Product in compliance with all applicable laws and regulations that regulate the inclusion or use of controlled substances, including without limitation, the EU RoHS Directive. **TOSHIBA ASSUMES NO LIABILITY FOR DAMAGES OR LOSSES OCCURRING AS A RESULT OF NONCOMPLIANCE WITH APPLICABLE LAWS AND REGULATIONS.**