

PCB-Mounted Type Current Transformer

(Without DC)

1. Specification:

CT Model NO.	Rated Current	Ratio		Load	Insulation voltage	Phase error	Accuracy
		Output Current	Turns				
CT006P-A/B/C	6A	2.4 / 3/ 4/ 6mA	1:1000	20 Ω	>3000V 1min	<15' <30'	Class 0.1 Class 0.2
CT010P- A/B/C	10A	4/5/10mA	1:1500				
CT020P- A/B/C	20A	8/10/20mA	1:2000				
CT030P- A/B/C	30A	12/15/20/30mA	1:2500				
CT100P	40A	16A/20mA	1:2000 1:2500	12.5 Ω	>3000V 1min	<15' <30'	Class 0.1 Class 0.2
CT101P	60A	24/30mA	1:2000 1:2500	12.5 Ω	>3000V 1min	<15' <30'	Class 0.1 Class 0.2
CT104P	100A	40mA	1:2500	10 Ω	>3000V 1min	<15' <30'	Class 0.1 Class 0.2
CT105P	120A	48mA	1:2500	10 Ω	>3000V 1min	<15' <30'	Class 0.1 Class 0.2

2. Features

- ★ AC measurement capacity is 20-30% higher than rated current
- ★ High accuracy. Completely suitable for high quality kWh meter with Class 1.0;
- ★ Small phase error. Typical phase shift is at 1-10'; Additional compensation not needed
- ★ Good insulation between Primary and Secondary, more than 3kV.
- ★ Very reliable and stable performance at different temperature conditions
- ★ Frequency: 50Hz/60Hz Ambient Temperature: -40°C--- +85°C
- ★ Many kinds of desirable bus-bars connected to the CT are available
- ★ **ROHS Compliance** is available on request

3. Size and Dimensions

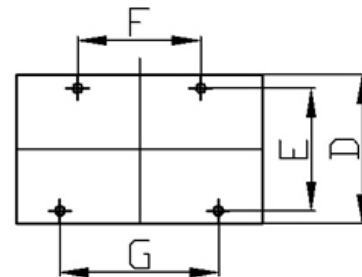
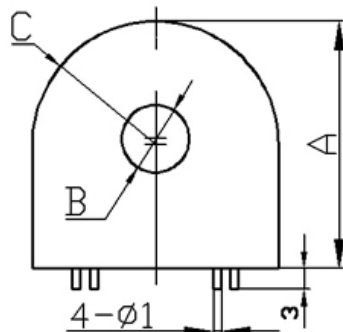

Model No.	Casing Type	Main Dimensions (mm)						
		A (Height)	B (Inner Hole)	2C (Width)	D (Thickness)	E	F	G
CT006P-A CT010P-A CT020P-A CT030P-A	A	30	8.2	30	18	15	15	19
CT006P-B CT010P-B CT020P-B CT030P-B	B	24.5	6.0	24	14.9	7.8	16.9	20.3
CT006P-C CT010P-C CT020P-C CT030P-C	C	25	6.8	24	11	10	15	19
CT100P	A	30	8.2	30	18	15	15	19
CT101P	A	30	8.2	30	18	15	15	19
CT104P	-	39	13	38	15	13	25	33
CT105P	-	39	13	38	15	13	25	33

3. Application

kWh Electric Meter without DC immunity

Replacement of Hall Sensor and shunt

4. Package

Good quality carton. Carton size: 37×26×30cm

CT006/010/020/030P-A, 780pcs/CTN, 24kg/CTN;

CT006P-B/C(used in 6A kWh meter), 900pcs/CTN, 14.5kg/CTN;

CT010P-B/C (used in 10A kWh meter), 900pcs/CTN, 14.5kg/CTN;

CT020P-B/C (used in 20A kWh meter), 900pcs/CTN, 15kg/CTN;

CT030P-B/C (used in 30A kWh meter), 900pcs/CTN, 15kg/CTN;

CT100P (used in 40-50A kWh meter), 780pcs/CTN, 24.7kg/CTN;

CT101P (used in 60A kWh meter), 780pcs/CTN, 25kg/CTN;

CT104P (used in 100A kWh meter), 600pcs/CTN, 28kg/CTN;

CT105P (used in 120A kWh meter), 600pcs/CTN, 28kg/CTN;